



User Manual INTD0805

Gen2 Replacement LED Lighting Strip Kit



- **Page 2** General Description
Specifications
Operation
- **Page 3** Connections

Please read carefully the instructions in order to get all the benefits of this device.

Caution!! The installation must be done from qualified technical personnel!

Gen2 Replacement
LED Lighting Strip Kit

INTD0805

www.pelekis.eu

REV 1.1

June 22, 2021



- General Description:

This device is intended for use in car LED lighting, when high quality uninterruptible main and backup LED lighting is needed (Using LED Strip lights as a source). Dedicated battery charging included, equipped with an SLA 12V/1.3Ah backup battery.

- Specifications

Power Supply	230V AC(50Hz) +/-15%
Led Light Output voltage	11.6VDC (+/-3%), (1.6A continuous). Up to 2 LED Strips lights 7.2W/metre can be connected (combined outputs).
Supported Battery	1 x SLA Type Battery - 12V 1.3Ah
Protections	Input overvoltage, undervoltage. Output overvoltage, short circuit, thermal hysteretic auto-restart.
Efficiency	85% (at 2 LED Strips lights /w Battery charging)
Operating conditions	Temp:0-60°C, Humidity: 10-80%
Dimensions (External)	110x210x70 mm (W x D x H)
Weight (Total/w Battery)	<1Kg

- Operation

Normal Mode:

The device will be in the normal mode while the main power supply 230VAC exists.

During normal operation, the INTD0805 device will drive the group of LED Strips Lights connected to “MAIN” connectors and they remain on while the “Interrupted 230VAC” is presented.

When the “Interrupted 230VAC” goes off the LED strips will turn off.

At this operation the battery is being charged/conditioned continuously.

Emergency Mode:

The device will automatically enter the Emergency mode when the main power supply 230VAC goes off.

During Emergency operation, the INTD0805 device automatically drives off the “MAIN” group of LED Strips, and turn on the “EMERGENCY” group of PELEKIS PCBs.

At this operation the battery is being discharged continuously.

Connections:

The INTD0805 device can operate in various connection setups and with various load combinations (using PELEKIS LED Strips Lights). A typical connection setup consists of:

- **Two LED Strips Lights as “MAIN”** light sources
- **Two PELEKIS LED PCBs Lights as “EMERGENCY”** light source
- **230VAC Main Power Supply as “MAINS”** connector!
- **Interrupted Input Signal from existing car light (230VAC) as “REMOTE”** connector on Controller!

A typical connection diagram is shown in Figure 1.

The operating modes truth table can be seen at Table1.

Figure 1. FRWD0805 typical connection diagram.

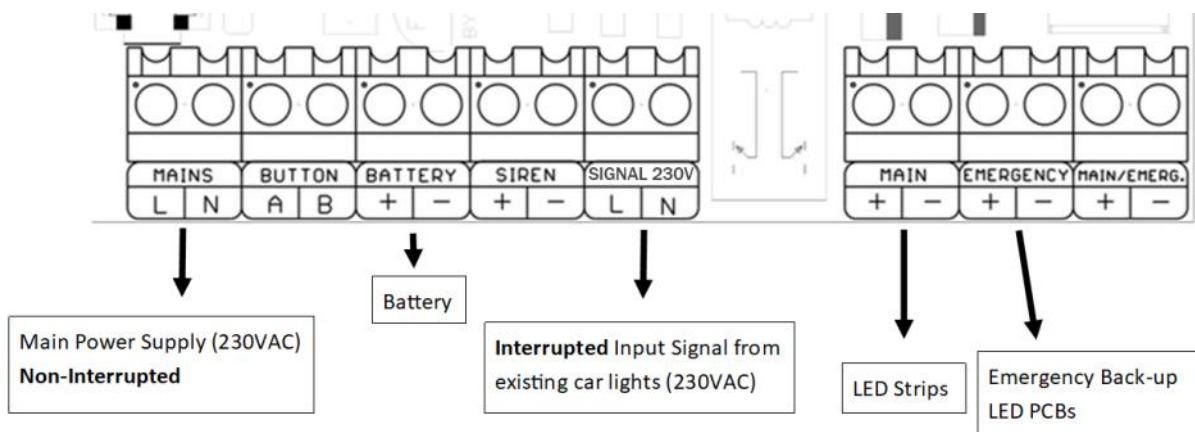

Table 1. INTD0805 Operating modes truth table.

INTD0805 Operating modes		
MODE	LED Strip Light connected to “MAIN”	PELEKIS LED PCBs Backup Lights connected to “EMERGENCY”
NORMAL (Interrupted 230VAC—ON)	LED Strips ON	PCBs OFF
NORMAL (Interrupted 230VAC—OFF)	LED Strips OFF	PCBs OFF
EMERGENCY	LED Strips OFF	PCBs ON



- **Technical support**

For technical support please contact the local distributor of Pelekis Electronics.

Pelekis Electronics Contact Info :

Tel. :+30 210 23 23 345

Fax :+30 210 23 86 382

E-mail : info@pelekis.eu

Website : www.pelekis.eu